

# Common Biology Program Learning Outcomes

---

Does your undergraduate biology major  
have program learning outcomes?

Be honest... How do you use program  
learning outcomes?

Admin hoop?

Program design?



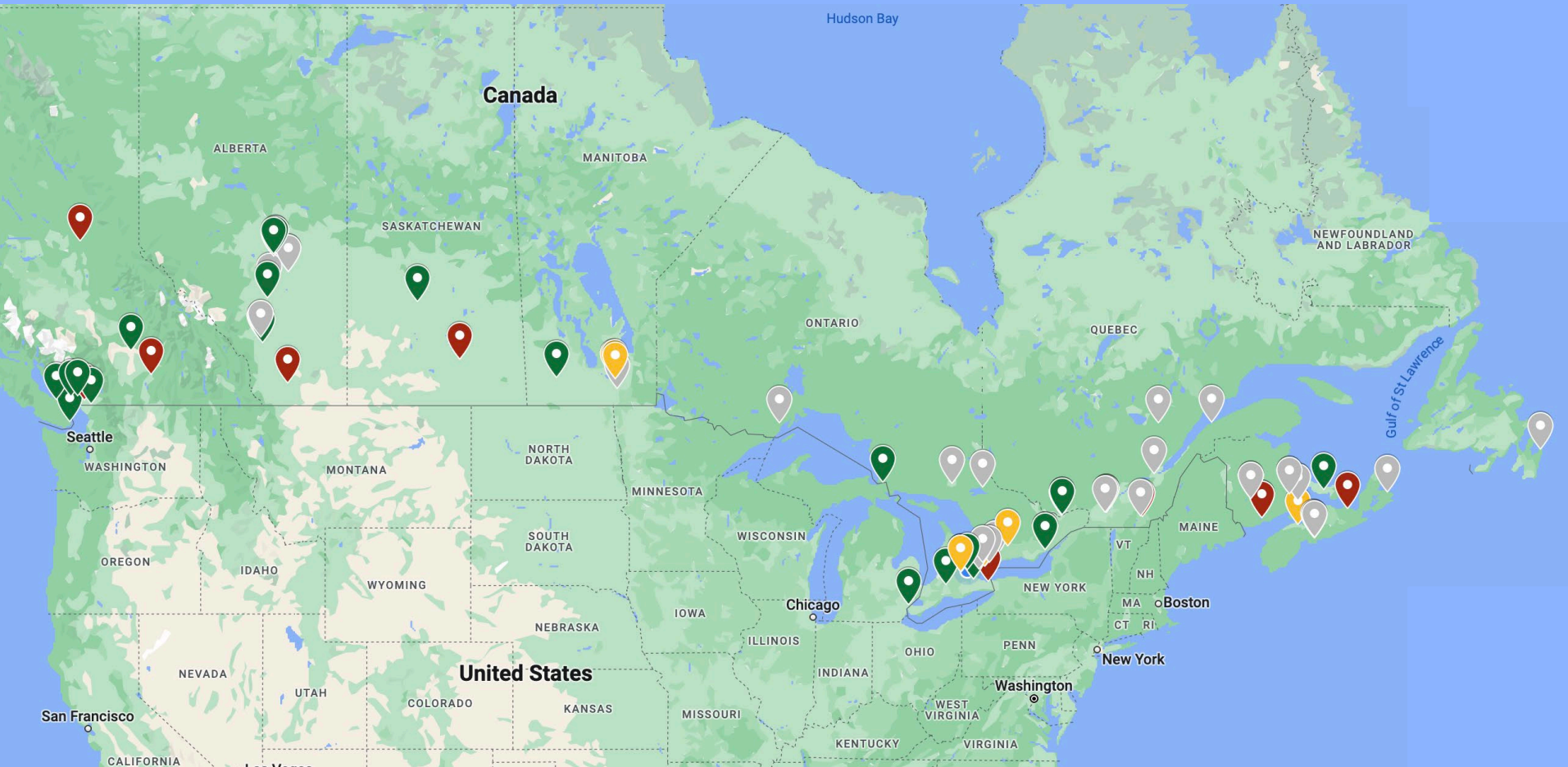

# Presentation Outcomes

1 Research Introduction

2 HELP!

3 Overall Thoughts?

# Introduction

- BSc Biology Program Learning Outcomes (PLOs)

The **knowledge, skills, and values** that students should acquire by the time they graduate.



**PLO Heading** →

**PLO** →

**Biological Science Learning Outcomes**

Problem Solving & Critical Thinking

PS1: Critically evaluate ideas and arguments by gathering and integrating relevant information, assessing its credibility, and synthesizing evidence to formulate a position.

PS2: Identify problems and independently propose solutions using creative approaches, acquired through interdisciplinary experiences, and a depth and breadth of knowledge/expertise.

**Communication**

C1: Accurately and effectively communicate ideas, arguments and analyses, to a range of audiences, in graphic, oral and written form.

# Why Care?

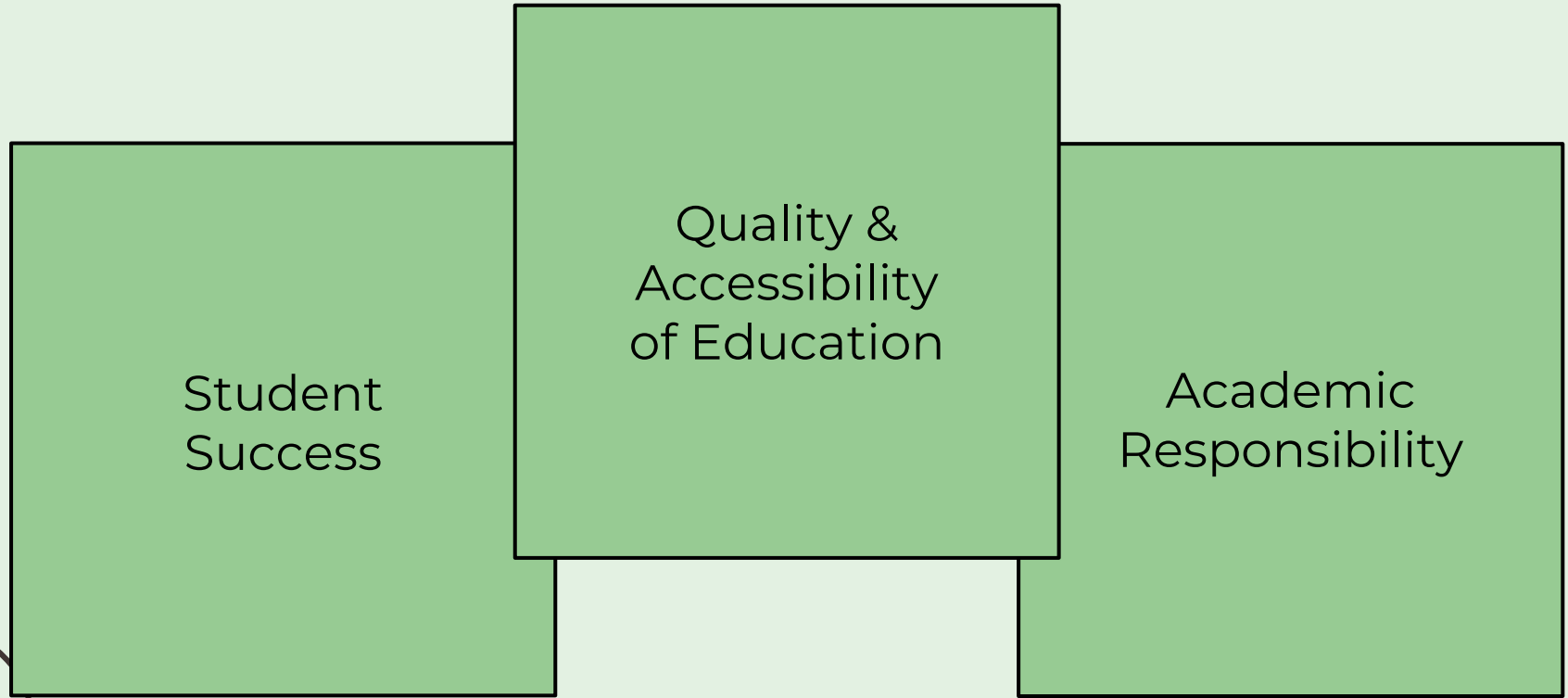

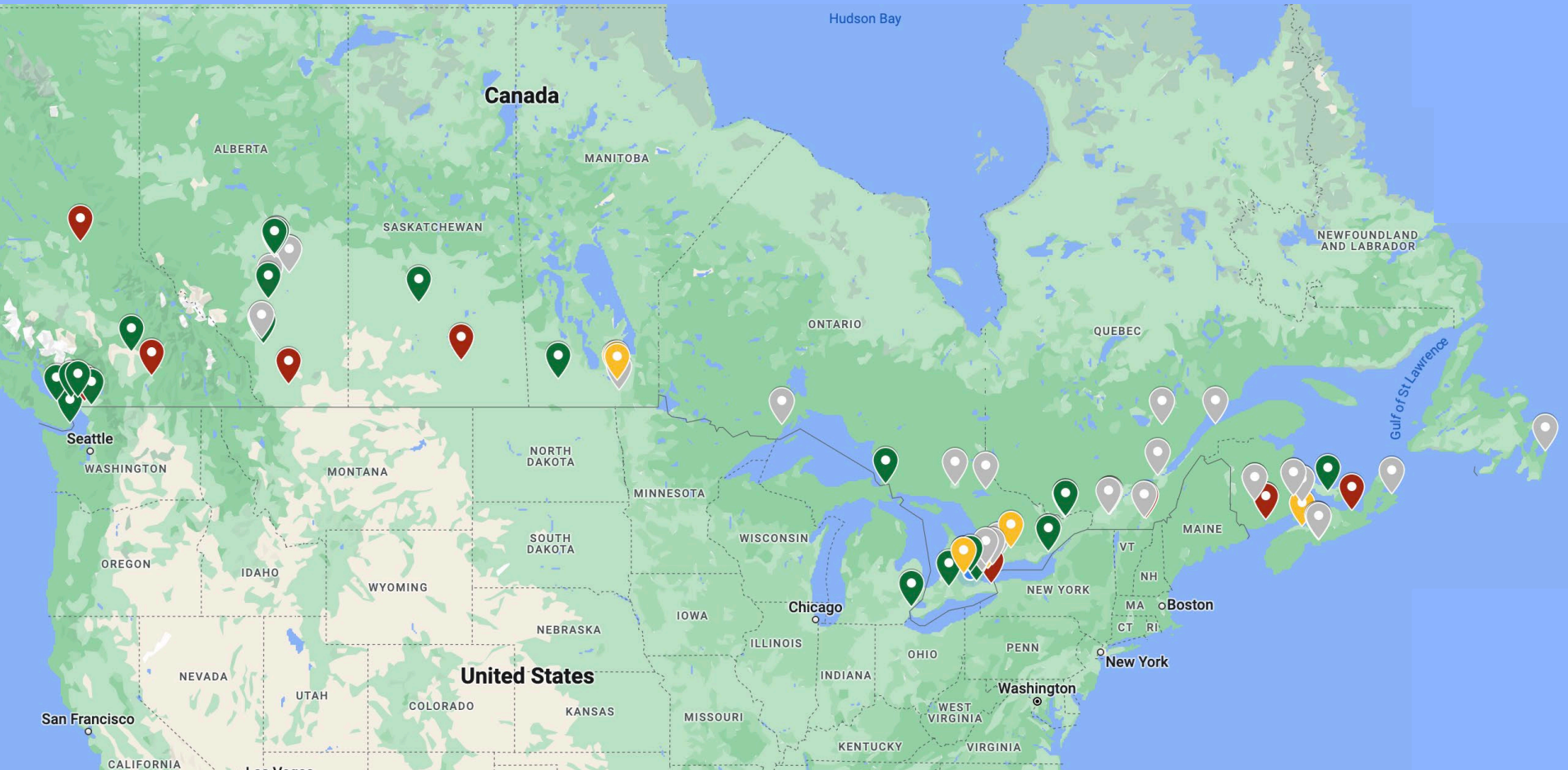

# Undergraduate Thesis Research

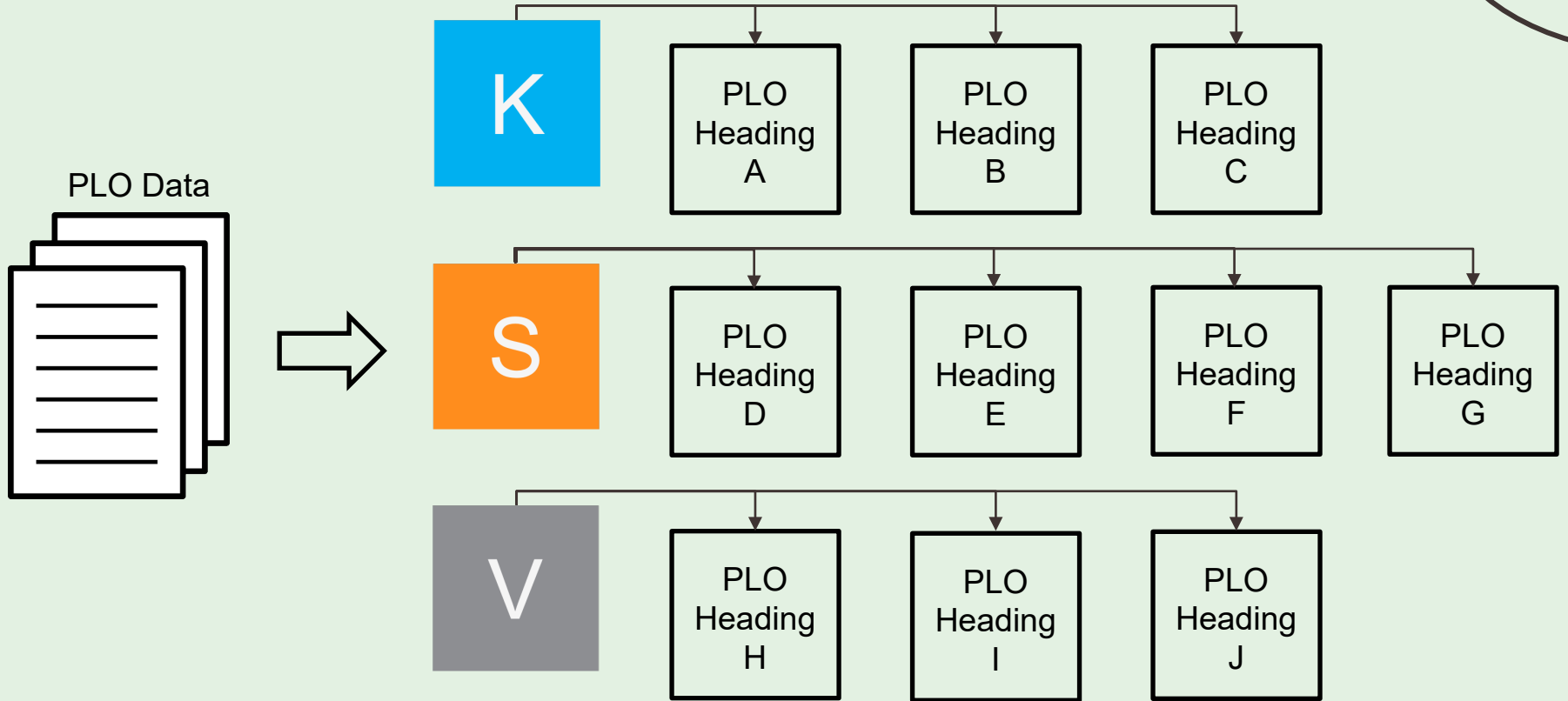



# Common PLO Framework

Knowledge

**PLO Heading A**

Description

- List of PLOs

**PLO Heading B**

Description

- List of PLOs

**PLO Heading C**

Description

- List of PLOs

Skills

**PLO Heading D**

Description

- List of PLOs

**PLO Heading E**

Description

- List of PLOs

**PLO Heading F**

Description

- List of PLOs

**PLO Heading G**

Description

- List of PLOs

Values

**PLO Heading H**

Description

- List of PLOs

**PLO Heading I**

Description

- List of PLOs

**PLO Heading J**

Description

- List of PLOs

## Aims

- 1) Applicable Common PLOs
- 2) Implementation Process

## The Plan

- 1) Validation
- 2) Test
- 3) Pre-Implementation
- 4) Implementation
- 5) Monitor

# Five Phases of Validation

- PLOs are revised after each phase of feedback

Phase I

Advisory Board → **Focus Group**

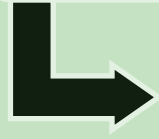

Phase II

Biology Chairs/Department Heads from Canadian Institutions → **Think Aloud Interviews**



Phase III

Biology Chairs/Department Heads from Canadian Institutions → **Focus Group Sessions**

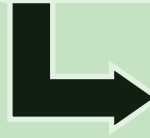

Phase IV

Biology Chairs/Department Heads from Canadian Institutions → **Survey**



Phase V

Biology Students → **Think Aloud Interview or Survey**

Help!

# Trial My Validation Process

**1) Part A:** Do this INDIVIDUALLY

Read the PLO and answer questions 1-4

**2) Part B:** Do this WITH YOUR GROUP

Read all the PLOs in the *Research & Lab Techniques* Heading

Answer questions 1 & 2

**3) Part C:** Do this WITH YOUR GROUP

Answer the 3 questions and *explain your reasoning* for each

Share some thoughts with the group 😊

Do you value having PLOs for your biology program?

Do you support the development and implementation of Common PLOs?

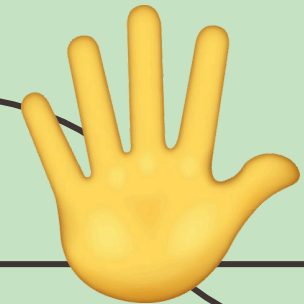

# Next Steps

- Advisory Board meeting
- Initiate Phase I of the PLO validation process

Scan the QR code to get involved!



# Let's Chat!

- When we have an implementation plan, where should it reside? The CCUBC?
- Where do we publish my results? What specifically should we publish?
- Do you care if biology PLOs are Canadian-based?
- PLO structure: verb, learning, context/criteria
- Any ideas of what institution might want to use an implementation plan as part of my thesis?
- Are biology Chairs/Department Heads the right people to be validating PLOs?
- Should employers be involved in the validation process?



---

**Thank You!**

---